

QUEUEING ANALYSIS OF DCHF AND HF TOKEN PROTOCOL WITH VARYING TURNAROUND TIME[†]

Manikanden Balakrishnan and Eric E. Johnson
New Mexico State University
{mabalakr, ejohnson}@nmsu.edu

ABSTRACT

Wireless Networks are generally characterized by a medium shared among a group of users. This makes an appropriate Media Access Control (MAC) protocol essential for efficient channel utilization. Wireless MAC protocols show significant performance degradation in some challenging networks (e.g., military HF radio) that are characterized by long link-layer turnaround times, and most of the recent research does not address this problem. This paper develops queueing and simulation models for wireless MAC protocols from two functional categories that are suitable for such networks: DCHF, a contention-based MAC protocol and the contention-free HF Token Protocol. We explore their statistical performance for varying link-layer turnaround times under varying Poisson loads. The results indicate the performance effects of factors such as link turnaround time, network size, and traffic loading on wireless MAC protocols.

1. INTRODUCTION

Media Access Control (MAC) protocols perform the channel allocation function when a channel is shared among a group of interfering nodes (typical of a wireless channel). The MAC protocol arbitrates among competing nodes in a network, and provides channel access to only one node at any instant. This channel access mechanism can either be centralized, wherein a master node allocates the channel to other nodes in the network sequentially, or distributed wherein individual nodes cooperatively perform the channel assignment function. Further, the MAC protocols can be functionally categorized as either contention-based or contention-free depending on the channel allocation method.

Contention-based MAC protocols require active nodes (nodes having traffic) to contend with each other for gaining channel access and the channel is assigned to the contention winner for data transmission time. This scheme does not introduce any management overhead, but multiple nodes transmitting at the same time is a possibility and so

collision-free operation is not guaranteed. Contention-based protocols can perform better by employing carrier-sensing (monitoring the channel to know its state) methods to reduce the probability of collisions.

Contention-free MAC protocols assign the channel to at most one node at any time for sending traffic and every node in the network gets its turn for accessing the channel. Collision free packet transmission is ensured and also, the nodes have prior knowledge of when to access the channel. However, contention-free schemes can incur considerable management overhead.

One of the factors that influence the performance of wireless MAC protocols is the link turnaround time, i.e., the time it takes for a node to process a packet upon reception and transmit a response. A detailed explanation of link turnaround time is given in [1]. For some challenging channels like high frequency (HF) skywave, extensive physical layer processing may result in turnaround times on the order of seconds; the performance of a wireless MAC protocol can degrade considerably in such cases.

This paper presents an analysis of the impact of turnaround times on the performance of two functional classes of wireless MAC protocols with arbitrary Poisson traffic in the network. Simulation models of the protocols are developed using NetSim [6] to substantiate the analytical results. Results of the analysis are then examined to identify an appropriate wireless MAC protocol for various network and traffic conditions.

1.1 Choice of the MAC protocols

Choice of a particular type of MAC protocol depends on the wireless network hardware and workload. An inappropriate MAC protocol can degrade the network performance significantly [1]. Distributed Coordination for High Frequency radio (DCHF) [1] is a contention-based scheme based on the popular wireless MAC protocol, IEEE 802.11 DCF [2] with some features incorporated from MACAW [3]. The other protocol analyzed here is the High Frequency Token Protocol (HFTP), a novel token passing scheme for channel access control proposed by Johnson et al., [4], which is shown to be efficient and reliable for HF radio networks. Further, the suitability of a token passing

[†]This work was supported by US Navy Space and Naval Warfare Systems Command; contract N660001-3287-2827LG

MAC scheme for wireless networks is evident from the research [1] and [5].

1.2 Related Work

The impact of turnaround time on wireless MAC protocols was investigated in [1]. The performances of DCHF and token-passing protocols were analyzed for varying turnaround times, but with a simple analytical model designed for saturated conditions. Bianchi [2] and Ergen [5] have thoroughly analyzed the performances of DCF and Wireless Token Ring Protocol (WTRP) respectively, but for saturated conditions and negligible link turnaround times. This paper extends these research works and provides a detailed investigation of the effects of lengthy link turnaround time on DCHF and HFTP, under varying Poisson loads.

2. PROTOCOL REVIEW

2.1 DCHF

DCHF is based on the IEEE 802.11 DCF with some features incorporated from MACAW. Like MACAW, DCHF uses only "virtual carrier sensing," a collision avoidance scheme in which nodes reserve the channel by including reservation information in transmitted packets. Other nodes, on receiving this information, defer their transmissions until the reservation time period expires. This approach addresses the inability of physical carrier sensing to prevent collisions when hidden stations are present [7], as well as the challenges of reliably sensing carrier in some challenging channels (e.g., HF skywave).

Virtual carrier sensing is implemented in DCHF via the Request-To-Send (RTS)/Clear-To-Send (CTS) handshake mechanism, as in DCF. A node having traffic to send will send a RTS control packet to the intended destination, if the channel is believed to be free. The destination responds with a CTS control packet. If this two way handshake is successful the sender node has acquired the channel for data transmission. The RTS and CTS packets include the reservation information (duration of packet transmission) and other nodes hearing the RTS/CTS exchange defer their transmissions till the time reserved has elapsed. During the reservation period collision-free data transmission takes place with MAC-layer acknowledgements sent for each received data packet. Data frames can be fragmented if the packet is too large to be sent in a single frame. In this case, each fragment is acknowledged before the transmission of next data fragment.

In the RTS-CTS-Data-Ack transmission sequence, each packet is separated by a Short Inter Frame Space (SIFS) and if the data is fragmented the Ack-DataFragment sequence is also separated by the same SIFS time. From [1] the length of SIFS is equivalent to a node's internal turnaround time.

$$\text{Internal Turnaround Time } (T_{IT}) = Y + d + g + h$$

Where,

Y = Time taken for carrier detection

d = Physical layer processing time for received packet

g = Mac layer processing time

h = Physical layer processing time for the response

A slotted contention window occurs whenever the channel becomes free, during which active nodes contend for channel access. The size of a slot is long enough to receive and process an RTS (or CTS) packet:

$$\text{Slot Time } (T_S) = b + T_{IT} + t$$

Where,

b = On-air duration of an RTS (or CTS) packet

T_{IT} = Internal turnaround time (time taken to process a control packet)

t = Channel propagation time

Also, Link turnaround time (T_l) = $T_{IT} + t$

An active node randomly chooses any one of the slots in the contention window to transmit its RTS packet, and it monitors the channel during the preceding slots. If no transmission is received during those preceding slots, the node transmits its RTS in the chosen slot and awaits a response. Other active nodes overhearing this RTS will defer their transmissions to avoid interfering with the response from destination node. The destination responds with a CTS packet in the next slot and nodes overhearing this CTS go to defer (idle) state till the time of transmission. This marks a successful channel acquisition that leads to collision-free data transmissions.

On the other hand, if the channel is acquired by some other node in the network during the backoff period, the contending node goes to defer state. Also if the RTS is not acknowledged with CTS, the node backs off and tries again later. The size of the contention window is doubled (up to a maximum value) if the channel acquisition is not successful, and is halved when it is successful (unlike DCF which sets the window size to minimum after success). By this scheme, the size of the contention window remains large during heavy congestion and hence collisions are reduced. As in MACAW, the window size of a node is transmitted along with the data packet (a field in the header) [3]. Nodes upon hearing a packet transmission set their current contention window size to the value in the packet header. DCHF provides fair allocation of channel resources, as all interfering nodes have the same back-off counter value after each successful packet transmission, which means equal opportunity to acquire the channel.

DCHF allows nodes with traffic to contend immediately for the channel; no synchronization among the nodes is needed. The protocol is self adjusting to nodes joining and leaving the network (no management overhead). Hidden station and partitioned network problems are addressed automatically by the protocol. However, the RTS/CTS

control packets represent channel overhead, and channel capacity is lost due to collisions (more when traffic is heavy). Nodes are not assured of channel access even if they have a lot of traffic to send, and the channel can be idle (all nodes backing off), even if the nodes have packets queued up.

2.2 HFTP

HFTP is based on a simple token passing mechanism that is optimized to work efficiently for HF networks. It incorporates additional management schemes for reliable recovery from lost or multiple tokens, dynamic node membership, recovering from link outages and hidden terminal problems to overcome the challenges of an unreliable HF channel. A detailed description of HFTP is given in [4]. Since the analysis of HFTP requires the understanding of basic token passing protocol, we provide a brief review of this scheme.

Token passing is a contention-free MAC protocol in which a token (explicit permission to transmit) is passed among the nodes in the network to decide the sender at any instant. A node possessing the token has the right to transmit on the channel for a specified duration of time (token holding time) after which the token gets passed on to the next node [4, 5, 8]. If a node does not have any traffic to send, it must immediately pass the token to the next node instead of holding the token for the token holding time.

The nodes in the network that receive data packets queue their link-layer acknowledgements and send them upon getting the token. Token acknowledgements are implicit; in the sense when a node hears transmission(s) from its successor node (to which the token is passed) it understands that the token has passed successfully, because nodes never transmit until they get the token.

A token passing protocol ensures that each node in the network gets a portion of the channel time and the nodes ensure that they never hold the channel if there is no traffic to send. However the token is an overhead packet in the network and passing the token between inactive nodes wastes some channel capacity. Token passing suits networks with heavy traffic. A principal concern in token-passing networks is the need to recover from lost or multiple tokens and to manage the entry and departure of network member nodes (which represents management overhead).

3. STATISTICAL ANALYSIS

Two standard performance metrics are used to analyze and compare DCHF and HFTP:

- *Average Latency per Packet* is the total delay suffered by a packet from the time it arrives at a node until the time it gets transmitted on the channel. This metric identifies the responsiveness of the protocols for varying traffic conditions.

- *Channel Utilization* is the fraction of total time the channel is being utilized to transmit bits and is a measure of the efficiency of these protocols.

Queueing models for these MAC protocols were developed to estimate the stated metrics. The network consists of 'N' nodes with each node having a mean packet arrival rate of 'l' packets per second. Packets arriving at a node are buffered in a FIFO queue and serviced one at a time. The packet inter-arrival times are exponential implying Poisson packet arrivals. The mean service rate of the channel is 'm' packets per second. The service time distribution is general; thus, DCHF and Token-Passing nodes are analyzed as M/G/1 queueing centers. Once the channel is acquired, a node is allowed to transmit only one data packet after which it relinquishes the channel.

3.1 DCHF model

The DCHF model builds upon previous work in modeling the IEEE 802.11 DCF [2] and a simple model of DCHF that was limited to saturation conditions [1]. Key differences between DCF and DCHF are

- DCHF excludes physical sensing of the channel and so the DCF Inter Frame Space (DIFS) time seen in DCF is omitted.
- Also the contention window size is not reset to minimum in DCHF when there is a successful transmission in the channel (like DCF), but is halved.

Figure 3.1 shows the basic model of DCHF.

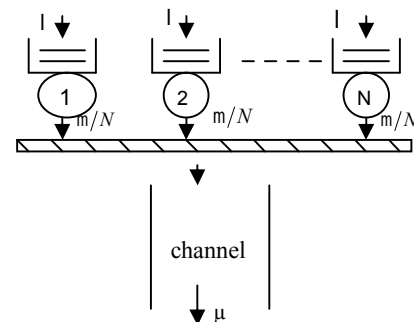

l - Packet Arrival Rate (packets/s)
 μ - Channel Service Rate (packets/s)
 N - Number of Nodes in the Network

Figure 3.1 DCHF model

Due to assumed symmetry in the packet arrival and service processes, the statistics are the same for every node. Unlike the earlier analysis of DCHF in [1], the model presented here allows for unsaturated conditions with arbitrary levels of Poisson traffic in the network.

Packets are serviced in FIFO order, and a node transmits only one packet when it acquires the channel after which the channel becomes free for servicing other nodes. The node that relinquished the channel goes through the contention process again if it has more packets to send. With arrival rate of 'l' packets per second and the channel ser-

vice rate of 'm' packets per second, the traffic intensity [9] in each node's queue is given by

$$\text{Node Queue Intensity } (\tau) = \frac{1}{(m/N)}$$

τ is the probability that a node has non-empty buffer (queue). When a contention period begins, a node contends for the channel if it has non-empty queue. Therefore the probability that a node contends is

$$\text{Probability of a node contending} = \tau$$

The average number of nodes contending for the channel in any contention window is

$$N_{\text{contending}} = N \tau$$

In this analysis, we use this mean value rather than weighting intermediate results using the actual probability distribution of $N_{\text{contending}}$ (see Mean-Value Analysis in [9]). The nodes randomly choose a slot during the contention process and in DCHF all the nodes have the same contention window size (S) at any instant. In this analysis we consider four possible values for S : 2, 4, 8 and 16 slots. A node's state is the size of its contention window at that instant. The window size starts from a minimum of 2 slots and increases to the next value of S when there is an unsuccessful acquisition attempt until the maximum value (16 slots) is reached; upon success the reverse process happens. The back-off algorithm can be analyzed with a Markov model shown in Figure 3.2, where the probability of success in state S is denoted as ' S_S '.

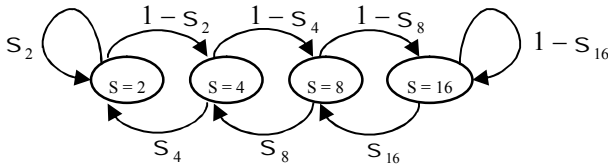

S_S - Probability of success in state S

Figure 3.2 Back-off behavior of DCHF

From [1], the probability that 'i' is the first occupied slot among S slots, when $N_{\text{contending}}$ nodes are contending for the channel is,

$$A_{S, N_{\text{contending}}}(i) = \left[\frac{S-i+1}{S} \right]^{N_{\text{contending}}} - \left[\frac{S-i}{S} \right]^{N_{\text{contending}}}$$

The expected value of first occupied slot in state S is,

$$A_{S, N_{\text{contending}}} = \sum_{i=1}^S i \left(\left[\frac{S-i+1}{S} \right]^{N_{\text{contending}}} - \left[\frac{S-i}{S} \right]^{N_{\text{contending}}} \right)$$

At any instant a node can be in any one of the four possible states and to estimate the state probabilities (P_S), we have to calculate the probability of success in each state given that $N_{\text{contending}}$ nodes are contending for the channel. The probability of success in slot 'i' is [1],

$$S_{S, N_{\text{contending}}}(i) = \frac{N_{\text{contending}}}{S} \left(\frac{S-i}{S} \right)^{N_{\text{contending}} - 1}$$

The overall probability of success in state S is given by,

$$S_S = \sum_{i=1}^S S_{S, N_{\text{contending}}}(i)$$

With the Markov model in Figure 3.2 we have a set of simultaneous equations that can be solved to get the state probabilities (P_S):

$$P_2 = \frac{1}{W}, \quad P_4 = \frac{P_2(1-S_2)}{S_4}, \quad P_8 = \frac{P_2(1-S_2)(1-S_4)}{S_4 S_8}$$

$$\text{and } P_{16} = \frac{P_2(1-S_2)(1-S_4)(1-S_8)}{S_4 S_8 S_{16}}$$

Where,

$$W = 1 + \frac{(1-S_2)}{S_4} + \frac{(1-S_2)(1-S_4)}{S_4 S_8} + \frac{(1-S_2)(1-S_4)(1-S_8)}{S_4 S_8 S_{16}}$$

The expected value of the first occupied slot in a contention process is

$$A = \sum_S P_S A_{S, N_{\text{contending}}}$$

and the probability of successful acquisition of the channel is

$$P_{\text{success}} = \sum_S P_S S_S$$

When a node finds the channel unoccupied during its monitoring stage, it sends an RTS in the chosen slot. If it receives a CTS in the next slot, that marks a successful channel acquisition. Then the node sends a data packet and receives an acknowledgement. The time taken to send an RTS, CTS or acknowledgement equals the slot time, T_S (described in the previous section), so the total time taken in case of success is

$$T_{\text{success}} = (A+2)T_S + T_{\text{pkt}}$$

where, T_{pkt} is the mean time taken to transmit one packet in the channel.

If the RTS that is transmitted in slot A is lost or collides with another transmission in the channel, the acquisition fails. The sender does not get CTS in the next slot and it assumes there was a collision in the channel. Other nodes in the network also detect this collision and do not transmit. A new contention process, with an increased number of contention slots, begins after the CTS slot. The total time taken in case of failed channel acquisition is

$$T_{\text{fail}} = (A+1)T_S$$

The service time of a packet is the time taken for a single packet to be transmitted successfully in the channel after it reaches the head of its queue, and is given by

$$\text{Channel Service Time} = T_{\text{success}} + T_{\text{fail}} \left(\frac{1}{P_{\text{success}}} - 1 \right)$$

where, $1/P_{\text{success}}$ denotes the average number of tries for a successful channel acquisition.

A packet on arrival to a node is stored in the buffer before getting serviced. Queuing Delay (T_q) represents the

time spent by a packet in node's buffer and for an M/G/1 model it is given by

$$T_q = \frac{1}{2} \frac{E(x^2)}{(1-r)}$$

where,

$E(x^2)$ is the expected second moment of the channel service time and r is the traffic intensity in a node queue.

Using these terms the average latency of a packet is calculated as

$$Latency_{average} = ChannelServiceTime + T_q$$

When all the nodes in the network have empty buffer, the channel is not used by any of the nodes in the network and that represents the fraction of time the channel is unutilized. Thus channel utilization is computed as

$$Channel\ Utilization = 1 - (1-r)^N$$

3.2 HFTP model

Nodes in the network pass the token among themselves and the node possessing the token transmits on the channel. Figure 3.3 shows the basic model of HFTP in steady state. The analysis is a generalization of [1] for arbitrary Poisson traffic in the network.

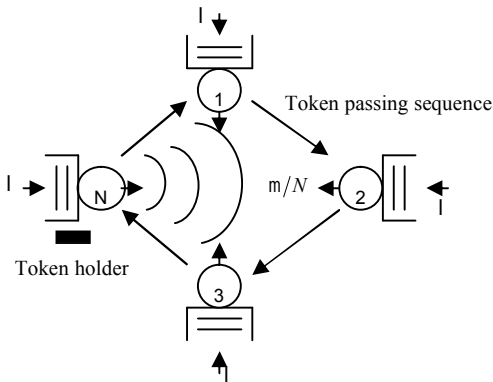

λ - Packet Arrival Rate (packets/s)
 μ - Channel Service Rate (packets/s)
 N - Number of Nodes in the Network

Figure 3.3 HFTP model

Each node upon receiving the token sends one data packet (if it has traffic to send), acknowledgements (if it has any) and then passes on the token to next node. Assuming symmetry in traffic destinations, each node will send, on average, as many acknowledgements as data packets. Hence the time delay per node is

$$T_{forward} = T_{token} + \frac{1}{(m/N)} (T_{pkt} + T_{ack}) + T_t$$

where,

T_{token} is the time for the token transit in the channel.

T_t is the link turnaround time

T_{ack} is the time taken to send an acknowledgement

$1/(m/N)$ is the probability that a node has an ack or data

Cycle Time is the average time taken for the token to complete one full rotation in the ring and is given by,

$$T_{cycle} = N T_{forward} + T_{mgmt}$$

where, T_{mgmt} represents the management overhead in HFTP per cycle and is here approximated as in [1].

$$T_{mgmt} = \frac{\sqrt{N}}{10} T_s$$

Where, T_s is the slot time and the value is same as in DCHF.

Channel Service Time of a packet depends on whether the incoming packet encounters an empty buffer or not. If the buffer is empty the packet arrival at the head of the queue is not synchronized with the token rotation cycle; hence the time it has to wait to be serviced will be, on average, half the cycle time. If the buffer is non-empty, the packet waits to reach the head of the FIFO queue and then waits to get serviced. In this case, the delay to get back the token will be the time taken for the rest of $N-1$ nodes to get served. The total latency suffered by a packet is the channel service time plus the queueing delay in the node's buffer.

$$Latency_{average} = \left(1 - \frac{1}{(m/N)}\right) \left[\frac{T_{cycle}}{2}\right] + \left(\frac{1}{(m/N)}\right) \left[\left(\frac{N-1}{N}\right) T_{cycle}\right] + T_q + T_{pkt}$$

Where,

$(1 - 1/(m/N))$ is the probability that an arriving packet encounters an empty buffer. This is same as the steady state empty buffer probability, since it is an open system.

T_q is the queueing delay and is same as in DCHF.

Channel Utilization can be computed in many ways. One way is finding the fraction of time the channel is unused. In HFTP, the nodes pass the token around even if they do not have traffic to send and so the turnaround times are the only time during which the channel is unutilized. Channel utilization is given by,

$$Channel\ Utilization = 1 - \frac{N T_t}{T_{cycle}}$$

3.3 Analytical Results

The results of the statistical analysis were obtained with the following parameter values (typical of an HF radio maritime wireless LAN):

- Channel transmission rate: 6400 bits/second
- Number of nodes in the network (N): 5 and 25
- RTS/CTS/Ack packet size: 30 Bytes
- Token size: 40 Bytes
- Data packet size: 1000 Bytes/packet (constant)

The performances of DCHF and HFTP in a small network with negligible link turnaround time (1ms) are shown in Figures 3.4 and 3.5. In HFTP even the inactive nodes are required to pass the token around and so the channel utilization is always high, given that the turnaround time is small. At light loads DCHF utilizes the channel more efficiently than HFTP as the token overhead exceeds the

amount of traffic in the network. HFTP has higher delay (per packet) than DCHF due to the token rotation among nodes. However, at heavy loads the DCHF performance degrades due to packet collisions.

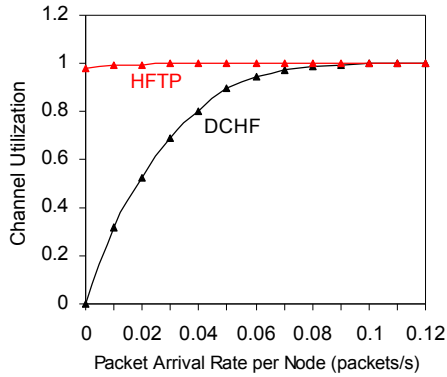

Figure 3.4 Channel utilization results for $T_t = 1ms, N = 5$

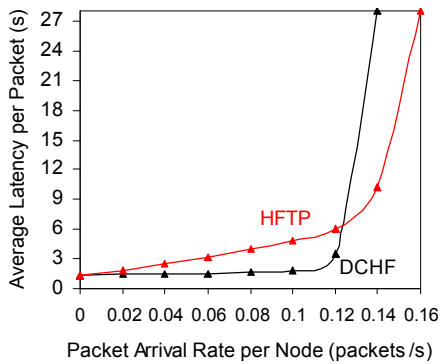

Figure 3.5 Latency results for $T_t = 1ms, N = 5$

Figures 3.6 and 3.7 show the performance of DCHF and HFTP for a long turnaround time (1s). As might be expected, the network performance degrades considerably (saturates much more rapidly). These results clearly show that HFTP has a superior performance than DCHF for small networks having lengthy turnaround times. The reduced channel utilization for HFTP when the traffic is light is due to longer idle periods while each node is in its turnaround time. HFTP exhibits better latency performance than DCHF, in spite of the token rotation. This is because the RTS/CTS hand shake in DCHF introduces two link

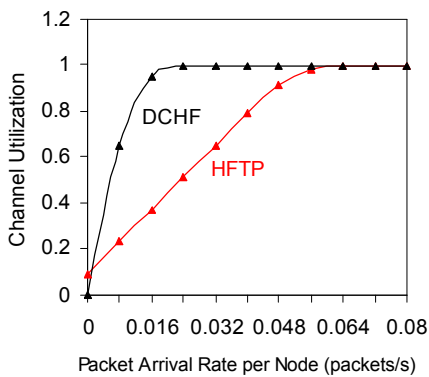

Figure 3.6 Channel utilization results for $T_t = 1s$ and $N = 5$

turnarounds, whereas passing token requires only one link turnaround per node, and this effect is significant when the turnaround times are huge.

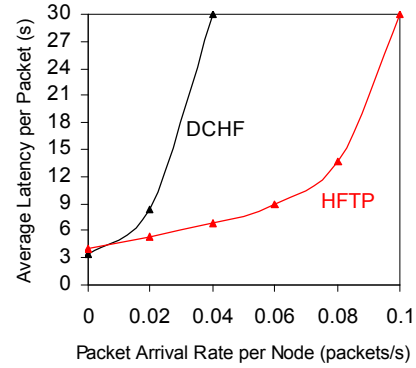

Figure 3.7 Latency results for $T_t = 1s$ and $N = 5$

Figures 3.8 and 3.9 show the performance of these protocols for large networks under long turnaround time (1s). At light loads, the latency performance of HFTP is noticeably worse than DCHF because the token gets passed among a large number of nodes (even with no traffic) with a delay of one link turnaround time per node, resulting in a large token rotation time, and therefore a large average channel access time. DCHF performs better than HFTP in large networks, since inactive nodes do not congest the channel. However, DCHF performance crashes at heavy traffic due to high packet collisions.

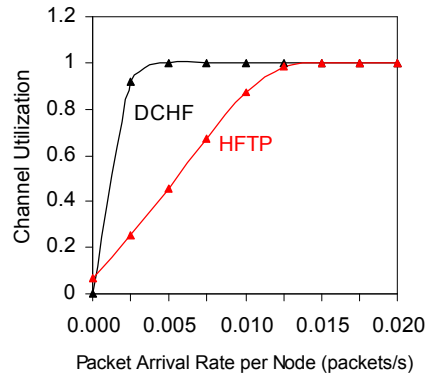

Figure 3.8 Channel utilization results for $T_t = 1s$ and $N = 25$

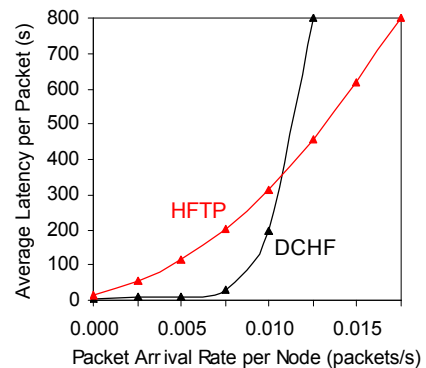

Figure 3.9 Latency results for $T_t = 1s$ and $N = 25$

4. SIMULATIONS

Simulation models of the DCHF and HFTP were developed using NetSim [6], a discrete event-driven network simulator, as a validation for the analytical results. The MAC module in the simulator was developed independently of the analytical model. However, identical assumptions and experimental conditions were used for the two models so that their results may be compared. Figure 4.1 shows one set of analytical results in comparison with the simulation results.

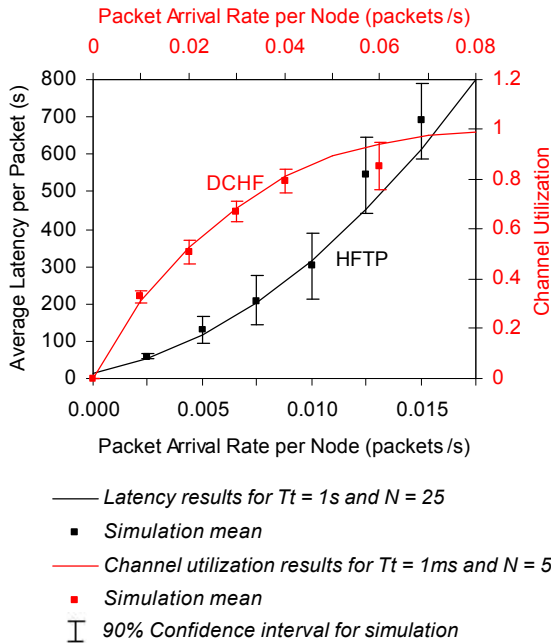

Figure 4.1 Simulation vs Analysis

In HFTP, the analytical and simulation results were obtained with the size of control and acknowledgement packets same as that of the token packet (40 bytes). Also, the management overhead was not approximated as in statistical analysis, but was considered to be null, to provide more accurate comparison results. All the other parameter values, assumptions and MAC functionalities, in the simulation design concur with those in the statistical analysis. The simulation results indicate good agreement with the corresponding analytical results.

5. DISCUSSION

Contention based MAC protocols are less sensitive to network size when compared to the contention free schemes, allowing dynamic joining and leaving of nodes, with the least amount of management overhead. Contention based schemes are attractive for lightly loaded networks, as the inactive nodes do not consume any channel capacity (unlike in token-passing), offering superior latency characteristics. However, under heavy traffic, contention free schemes utilize the channel better as they dynamically pre-schedule the channel, allowing collision free data trans-

missions. Packet collisions are the main source of channel wastage in contention based protocols and they occur more often under heavy loading. The amount of channel capacity wasted due to collisions is severe when the link turnaround times are lengthy, since the RTS/CTS collisions may result in several unsuccessful hand shake attempts (with two turnaround times per hand shake), accounting to huge average channel access latency.

5.1 Conclusions

In this paper, a statistical analysis of two functional categories of wireless MAC protocols was performed under varying link turnaround times. The performances were measured with varying Poisson loads. The analysis proves that link turnaround times and network traffic influence the performance of MAC protocols significantly. Contention free schemes are more suitable for small networks with long turnaround times, under light or heavy loading, since the packet collisions and delay introduced by collision-avoidance schemes in contention based protocols make them ineffective. However for large networks with light traffic, contention based schemes are appropriate, since the management overhead and synchronization schemes in contention-free protocols outweigh the channel time spent for transmitting data.

5.2 Future Work

Effects of packet losses (common in realistic channels) on the statistical performance of wireless MAC protocols should be analyzed and verified using simulations, modeled with a realistic lossy channel. Future work can also include an investigation of the overhead imposed on wireless MAC protocols due to high node mobility that leads to constant changes in network size and topology.

REFERENCES

- [1] E.E. Johnson et al., "Impact of Turnaround Time on Wireless MAC Protocols," *Proceedings of MILCOM 2003*, IEEE, Boston, October 2003.
- [2] G. Bianchi, "Performance Analysis of the IEEE 802.11 Distributed Coordination Function," *IEEE Journal on Selected Areas in Communications* 18 (3), pp. 535-547, March 2000.
- [3] V. Bharghavan et al., "MACAW, A Media Access Protocol for Wireless LANs," *Proceedings of SIGCOMM '94*, ACM, 1994.
- [4] E.E. Johnson et al., "Robust Token Management for Unreliable Networks," *Proceedings of MILCOM 2003*, IEEE, Boston, October 2003.
- [5] M. Ergen et al., "Wireless Token Ring Protocol," *SCI 2002*.
- [6] E.E. Johnson, "Simulation Results for Third-Generation HF Automatic Link Establishment," *Proceedings of 1999 IEEE Military Communications Conference (MILCOM 1999)*, IEEE, Atlantic City, NJ, October 1999.
- [7] C.K. Toh, *Ad Hoc Mobile Wireless Networks: Protocols and Systems*, Prentice Hall, 2001.
- [8] ANSI/IEEE Standard 802.4: Token-Passing Bus Access Method and Physical Layer specifications, 1985.
- [9] R. K. Jain, *The Art of Computer Performance Analysis*, John Wiley and Sons, 1992.